

# Shoebbox Guitar

## MATERIALS

Shoebbox (or other small cardboard box)

3 or 4 rubber bands

Scissors or X-acto knife

A pencil

Ruler

Tape

## MAKING THE GUITAR

A grown-up will need to help you with the cutting.

1. Cut a hole in the top of the shoebbox.

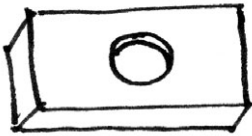

2. Wrap 3 or 4 rubber bands around the box like this.



3. Slip a pencil under the rubber bands just about here.

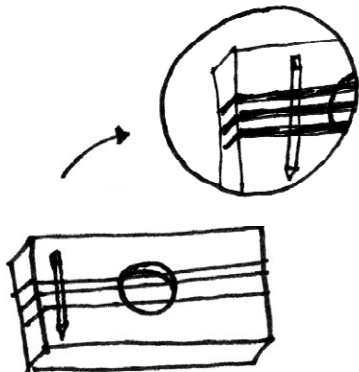

4. Tape the ruler to the back side of the box.

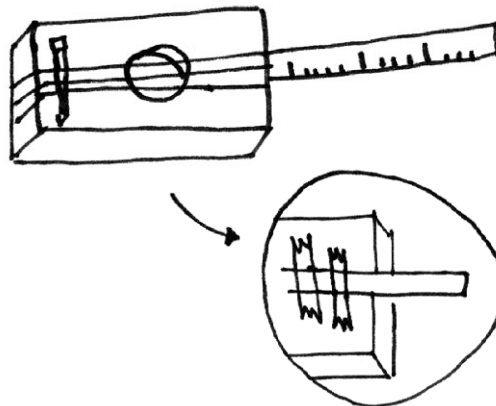

5. Decorate it like crazy with glitter or stickers or drawings.

6. Strum away!

# Cup Shaker

## MATERIALS

Plastic cup

Uncooked rice, dried beans or lentils

A lid for the cup, or paper and tape

1. Put rice or beans or lentils in your cup.
2. Place a lid on your cup, or, if you don't have a lid you can seal it up by taping a piece of paper over the top.
3. Shake, shake, shake!  
(keep your hand over the top as you go)

